

Technical documentation



# **VOLCANO**

**VOLCANO VR Mini**  
**VOLCANO VR1**  
**VOLCANO VR2**  
**VOLCANO VR3**  
**VOLCANO VR-D**

Check us on



**TABLE OF CONTENTS**

1.1 PRECAUTIONS, REQUIREMENTS, RECOMMENDATIONS .....	3
1.2 TRANSPORT .....	3
1.3 INITIAL STEPS TAKEN BEFORE THE INSTALLATION .....	3
2. STRUCTURE, INTENDED USE, PRINCIPLE OF OPERATION .....	3
2.1 INTENDED USE .....	3
2.2 PRINCIPLE OF OPERATION .....	3
2.3 DEVICE STRUCTURE (VOLCANO) .....	4
3. TECHNICAL DATA .....	5
4. ASSEMBLY .....	8
4.1 INSTALLATION WITH A BRACKET .....	9
4.2 INSTALLATION INSTRUCTIONS AND MOUNTING DISTANCES .....	10
5. AUTOMATICS .....	12
5.1 ELEMENTS OF AUTOMATICS .....	12
6. START-UP, OPERATION, MAINTENANCE .....	12
6.1 START-UP/PUTTING INTO OPERATION .....	12
6.2 OPERATION AND MAINTENANCE .....	12
7. INDUSTRIAL SAFETY INSTRUCTION .....	13
8. SERVICING .....	13
8.1 PROCEDURES IN CASE OF DEFECTS .....	13
8.2 COMPLAINT PROCEDURE .....	14
9. ELECTRICAL DIAGRAMS .....	15
9.1. Connection of Volcano VR Mini, VR1, VR2, VR3, VR-D to the HMI VR controller .....	15
9.2. Connection of Volcano VR Mini, VR1, VR2, VR3 to the HMI VR controller and valve actuator .....	15
9.3. Connection of Volcano VR Mini, VR1, VR2, VR3 to the HMI VR controller and external temperature sensor .....	16
9.4. Connection of Volcano VR Mini, VR1, VR2, VR3 to the HMI VR controller, valve actuator and external temperature sensor .....	16
10. VTS STANDARD WARRANTY TERMS AND CONDITIONS FOR EUROHEAT PRODUCTS .....	18
11. TABLE OF INSPECTION AND MAINTANANCE .....	19

## 1. INTRODUCTION

### 1.1 PRECAUTIONS, REQUIREMENTS, RECOMMENDATIONS

Read the documentation carefully, install and use the equipment according to the specifications, and follow all the safety regulations in order to ensure proper and safe use of the device. Any use that is incompatible with these instructions can cause serious injuries. Restrict access by unauthorized persons and train the operational personnel. The term **operational personnel** refers to people who are suitably trained and have appropriate experience and knowledge of relevant norms, documentation and occupational health and safety regulations, and are authorized to conduct the required work and can identify possible threats and avoid them. This operation and maintenance manual, which is delivered with the device, includes detailed information on all possible configurations of the heaters, examples of their assembly, start, use, repair and maintenance. To operate this device correctly, this manual includes instructions sufficient for qualified personnel. **The documentation should be placed close to the device for ease of access by the service team. The manufacturer reserves the right to introduce changes to the manual or the specifications of the device, which may alter its operation, without prior notice. VTS POLSKA Sp. z o.o. shall not be held liable for current maintenance, servicing, programming, damage caused by standstill of the device awaiting warranty service, any damage to customer's possessions other than the device, or faults resulting from the wrong assembly or use of the device.**

### 1.2 TRANSPORT

Prior to the installing and taking the device out of the cardboard box, it is required to check whether the cardboard box has not been damaged in any way and/or the adhesive tape (installed at the company) has not been broken off or cut. It is recommended to check whether the device's casing has not been damaged in transport. Should any of the above situation occur, please contact us through telephone or e-mail: Tel. 0 801 080 073, email: vts.pl@vtsgroup.com, fax: (+48) 12 296 50 75. **The device should be transported by two people. Use appropriate tools, when transporting the device, so as to avoid the damaging of goods and potential hazard to health.**

### 1.3 INITIAL STEPS TAKEN BEFORE THE INSTALLATION

Record the **serial number** of the device in the warranty card, prior to the commencement of the installation process. **It is required to properly fill-in the warranty card, after the completion of the assembly.** Prior to the commencing of any installation or maintenance work, it is required to disconnect power supply and protect it against unintentional activation.

## 2. STRUCTURE, INTENDED USE, PRINCIPLE OF OPERATION

### 2.1 INTENDED USE

VOLCANO VR has been designed to ensure ease of use and optimum performance.

The device is available in five versions:

- VOLCANO VR Mini (10-68 MBH, 1236 CFM)
- VOLCANO VR 1 (17-102 MBH, 3119 CFM)
- VOLCANO VR 2 (27-170 MBH, 2855 CFM)
- VOLCANO VR 3 (44-256 MBH, 3355 CFM)
- VOLCANO VR-D (3826 CFM)

VOLCANO combines state-of-the-art technology, innovative design and high effectiveness. Unique technical solutions such as the design of the heat exchanger, improved fan and increased range of air stream, allow the VOLCANO heater to achieve optimal heating power, perfect for the size and type of room. **APPLICATION:** production halls, warehouses, wholesale outlets, sports facilities, greenhouses, supermarkets, church buildings, farm buildings, workshops, health care facilities, pharmacies, hospitals. **MAIN ADVANTAGES:** high effectiveness, low maintenance costs, full parameter control, easy and quick assembly.

### 2.2 PRINCIPLE OF OPERATION

The heating medium (hot water) gives up heat to the heat exchanger using a highly developed heat exchanger, ensuring great heating power (Volcano VR Mini – 10-68 MBH, VR 1 – 17-102 MBH, VR 2 – 27-170 MBH, VR 3 – 44-256 MBH). A highly effective axial fan (674-3355 m<sup>3</sup>/h) draws air in from the room, pumps it through the heat exchanger and then sends it back into the room.

Volcano VR-D de-stratifies the heated air from the sub-ceiling zone to the above-ground zone. Hot air exhaust results in a leveling of the temperature gradient in particular air layers and contributes to reducing the costs of heating by lowering the temperature in the ceiling zone, thus limiting heat loss through the roof. The VOLCANO VR-D de-stratifier will be the most effective in combination with VR Mini, VR1, VR2 and VR3 air heaters. Cooperation of both of these device types will allow for achieving optimal temperature comfort fast due to the support of the heating system through more efficient distribution of hot air.

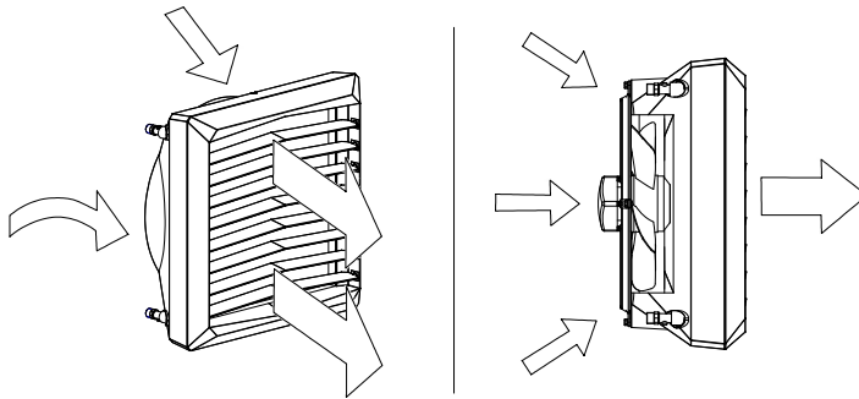

### 2.3 DEVICE STRUCTURE (VOLCANO)

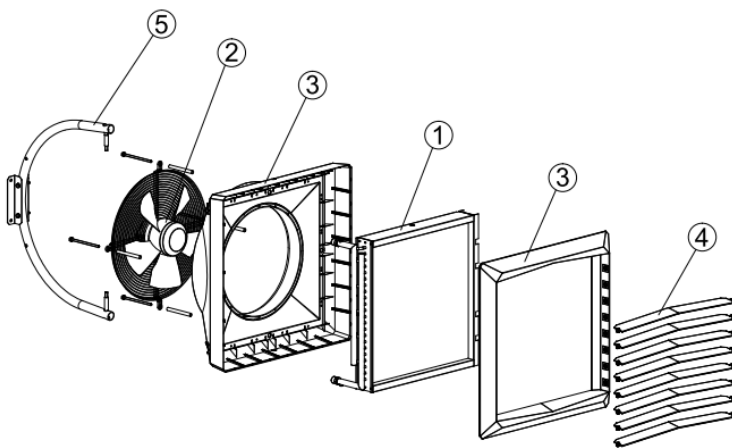

- 1. HEAT EXCHANGER;
- 2. AXIAL FAN;
- 3. COVER;
- 4. AIR GUIDES;
- 5. SAMPLE CONSOLE

**1. HEAT EXCHANGER:** maximum parameters of a heating medium for a heat exchanger are: 266°F, 232PSI. Aluminium and copper construction using copper tubes, coil pipe and aluminium lamellas. Connecting ferrules (male thread ¼") are on the back panel of the unit. Our series of types includes a single-row heat exchanger in VOLCANO VR1 17-102 MBH and two-row heat exchanger in VOLCANO VR Mini 10-68 MBH and VOLCANO VR2 27-170 MBH and in VOLCANO VR3 44-256 MBH - three-row heat exchanger.

**2. AXIAL FLOW FAN:** maximum working temperature is 140°F, nominal power supply voltage is 120/60Hz or 240V/50Hz. EC Engine protection is IP44, insulation class F. Air feed is performed by the axial flow fan, which is secured with a protective grate. Adequate blade profile and proper bearings guarantee silent and unfailling operation of the device. High engine power allows for achieving high efficiency at low power consumption rates, maintaining full air feed regulation. Properly profiled housing lowers the noise emission levels, which makes the device particularly user-friendly, suitable for buildings with higher acoustic requirements.

**3. HOUSING:** consists of the body and the front panel, made of high quality plastic guaranteeing compatibility with devices powered by heating medium with temperature parameter up to 266°F. Colorful side panels allow for matching the device color to the interior décor. Volcano VR-D operates circulation air, improving its distribution and performing the de-stratification function.

**4. AIR GUIDES:** allow the hot air stream to be directed in 4 directions. Optimum air stream range and direction are achieved through the special fan blade profile.

**5. ASSEMBLY CONSOLE:** an element of additional equipment - its ergonomic, light structure allows for rotating the device on the horizontal plane for  $-140^{\circ} \div 0 \div 140^{\circ}$ , to direct the stream of hot air wherever it is necessary.

### 2.4 OVERALL DIMENSIONS

#### VOLCANO VR Mini

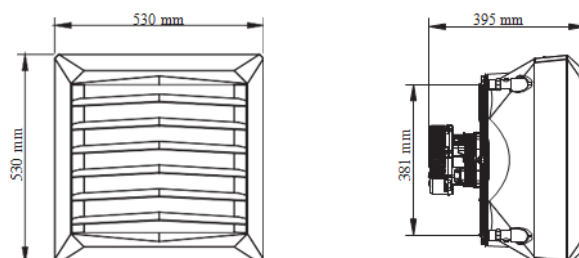

VNO VR1, VR2, VR3, VR-D

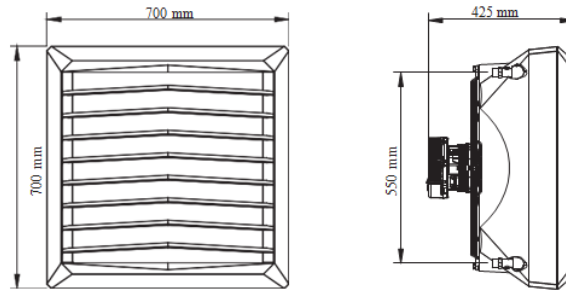

3. TECHNICAL DATA

$T_z$  – inlet water temperature;  $T_p$  – outlet water temperature;  $T_{p1}$  – inlet air temperature;  $T_{p2}$  – outlet air temperature;  $P_g$  – heating capacity;  $Q_w$  – water flow;  $Q_p$  – air flow rate;  $\Delta p$  – pressure drop in the heat exchanger

Volcano VR mini																	
Parameters $T_z/T_p$ [°F]																	
194/158						176/140				158/122				122/86			
$T_{p1}$ [°F]	$Q_p$ [CFM]	$P_g$ [MBH]	$T_{p2}$ [°F]	$Q_w$ [CFM]	$\Delta p$ [psi]	$P_g$ [MBH]	$T_{p2}$ [°F]	$Q_w$ [CFM]	$\Delta p$ [psi]	$P_g$ [MBH]	$T_{p2}$ [°F]	$Q_w$ [CFM]	$\Delta p$ [psi]	$P_g$ [MBH]	$T_{p2}$ [°F]	$Q_w$ [CFM]	$\Delta p$ [psi]
32	1236	70,6	85,1	0,54	2,0	61,1	77,7	0,46	1,6	51,5	70,5	0,39	1,1	31,4	55,6	0,24	0,5
	971	61,8	90,7	0,47	1,6	53,2	82,8	0,41	1,2	44,7	74,7	0,34	0,9	27,3	58,3	0,21	0,4
	647	48,1	100,9	0,37	1,0	41,6	91,8	0,32	0,8	35,1	82,2	0,26	0,6	21,5	63,0	0,16	0,2
41	971	57,7	96,1	0,44	1,4	56,6	83,5	0,43	1,3	46,7	76,1	0,35	1,0	25,9	61,0	0,20	0,4
	1236	66,2	90,7	0,51	1,8	49,5	88,0	0,38	1,0	40,9	79,9	0,31	0,8	23,2	63,3	0,18	0,3
	647	45,4	105,6	0,35	0,9	38,6	96,4	0,29	0,7	32,1	86,9	0,24	0,5	18,4	67,3	0,14	0,2
50	1236	61,8	96,3	0,47	1,6	52,2	89,1	0,39	1,2	42,3	81,7	0,32	0,8	21,8	66,4	0,16	0,2
	971	53,9	95,9	0,41	1,2	45,4	93,4	0,35	0,9	36,9	85,1	0,28	0,6	19,1	68,2	0,14	0,2
	647	42,3	110,3	0,32	0,8	35,5	100,9	0,27	0,6	29,0	91,4	0,22	0,4	15,0	71,4	0,11	0,1
59	1236	57,3	101,8	0,44	1,4	47,4	94,6	0,36	1,0	37,5	87,3	0,28	0,6	16,7	71,6	0,13	0,2
	971	49,8	106,5	0,38	1,1	41,3	98,6	0,32	0,8	32,8	90,3	0,25	0,5	14,7	73,0	0,11	0,1
	647	39,2	115,0	0,30	0,7	32,4	105,6	0,25	0,5	25,9	95,9	0,19	0,3	11,3	75,4	0,09	0,1
68	1236	52,9	107,4	0,41	1,2	43,0	100,2	0,33	0,8	33,1	92,7	0,25	0,5	11,3	76,5	0,08	0,1
	971	46,1	111,7	0,35	0,9	37,5	103,6	0,28	0,6	28,7	95,4	0,22	0,4	9,6	77,2	0,07	0,1
	647	36,2	119,5	0,28	0,6	29,3	110,1	0,22	0,4	22,5	100,4	0,17	0,3	6,5	77,4	0,05	0,03

$T_z$  – inlet water temperature;  $T_p$  – outlet water temperature;  $T_{p1}$  – inlet air temperature;  $T_{p2}$  – outlet air temperature;  $P_g$  – heating capacity;  $Q_w$  – water flow;  $Q_p$  – air flow rate;  $\Delta p$  – pressure drop in the heat exchanger

Volcano VR1																	
Parameters $T_z/T_p$ [°F]																	
194/158						176/140				158/122				122/86			
$T_{p1}$ [°F]	$Q_p$ [CFM]	$P_g$ [MBH]	$T_{p2}$ [°F]	$Q_w$ [CFM]	$\Delta p$ [psi]	$P_g$ [MBH]	$T_{p2}$ [°F]	$Q_w$ [CFM]	$\Delta p$ [psi]	$P_g$ [MBH]	$T_{p2}$ [°F]	$Q_w$ [CFM]	$\Delta p$ [psi]	$P_g$ [MBH]	$T_{p2}$ [°F]	$Q_w$ [CFM]	$\Delta p$ [psi]
32	3119	102,0	62,2	0,78	3,8	88,0	58,1	0,67	2,9	74,0	54,0	0,56	2,1	45,0	45,5	0,34	0,9
	2295	86,7	66,9	0,66	2,8	74,7	62,1	0,57	2,1	62,8	57,4	0,48	1,6	38,6	47,5	0,29	0,7
	1648	72,3	72,7	0,55	2,0	62,4	67,1	0,48	1,5	52,5	61,5	0,40	1,1	32,1	50,2	0,24	0,5
41	3119	95,5	69,4	0,73	3,3	81,6	65,1	0,62	2,5	67,2	61,0	0,51	1,8	38,6	52,3	0,29	0,7
	2295	81,2	73,8	0,62	2,5	69,3	68,9	0,53	1,9	57,3	64,0	0,44	1,3	32,8	54,1	0,25	0,5
	1648	67,9	79,2	0,52	1,8	57,7	73,6	0,44	1,3	47,8	67,8	0,36	1,0	27,3	56,5	0,21	0,4
50	3119	89,1	76,5	0,68	2,9	75,1	72,3	0,57	2,1	60,7	68,0	0,46	1,5	31,4	59,4	0,24	0,5
	2295	75,7	80,6	0,58	2,2	63,8	75,7	0,48	1,6	51,5	70,9	0,39	1,1	27,0	60,8	0,20	0,3
	1648	63,1	85,5	0,48	1,5	53,2	79,9	0,41	1,1	43,3	74,3	0,33	0,8	22,5	62,6	0,17	0,3
59	3119	82,6	83,5	0,63	2,5	68,2	79,3	0,52	1,8	53,9	75,0	0,41	1,2	24,6	66,2	0,18	0,3
	2295	69,9	87,3	0,54	1,9	58,0	82,4	0,44	1,3	46,1	77,5	0,35	0,9	20,8	67,5	0,16	0,2
	1648	58,7	91,9	0,45	1,3	48,5	86,4	0,37	1,0	38,6	80,6	0,29	0,6	17,4	68,7	0,13	0,2
68	3119	75,7	90,5	0,58	2,2	61,8	86,4	0,47	1,5	47,1	82,0	0,36	0,9	17,1	73,0	0,13	0,2
	2295	64,5	94,1	0,49	1,6	52,5	89,2	0,40	1,1	40,3	84,2	0,31	0,7	14,3	73,8	0,11	0,1
	1648	53,9	98,2	0,41	1,1	44,0	92,7	0,34	0,8	33,8	86,9	0,25	0,5	11,9	74,7	0,09	0,09

**VOLCANO VR Mini**  
**VOLCANO VR1**  
**VOLCANO VR2**  
**VOLCANO VR3**  
**VOLCANO VR-D**

T<sub>z</sub> – inlet water temperature; T<sub>p</sub> – outlet water temperature; T<sub>p1</sub> – inlet air temperature; T<sub>p2</sub> – outlet air temperature; P<sub>g</sub> – heating capacity; Q<sub>w</sub> – water flow; Q<sub>a</sub> – air flow rate; Δp – pressure drop in the heat exchanger

Volcano VR2																	
Parameters T <sub>z</sub> /T <sub>p</sub> [°F]																	
194/158						176/140				158/122				122/86			
Tp1 [°F]	Qp [CFM]	Pg [MBH]	Tp2 [°F]	Qw [CFM]	Δp [psi]	Pg [MBH]	Tp2 [°F]	Qw [CFM]	Δp [psi]	Pg [MBH]	Tp2 [°F]	Qw [CFM]	Δp [psi]	Pg [MBH]	Tp2 [°F]	Qw [CFM]	Δp [psi]
32	2855	170,9	87,3	1,30	3,5	147,1	79,7	1,12	2,7	123,5	72,1	0,94	2,0	76,1	56,7	0,57	0,8
	2119	143,0	94,5	1,09	2,5	124,5	86,0	0,94	1,9	104,1	77,5	0,79	1,4	64,1	60,1	0,48	0,6
	1413	111,6	105,1	0,85	1,6	96,6	95,4	0,74	1,2	81,6	85,5	0,62	0,9	50,5	65,1	0,38	0,4
41	2855	159,3	92,7	1,22	3,1	136,1	85,1	1,04	2,3	112,9	77,5	0,85	1,7	64,8	62,1	0,49	0,6
	2119	134,1	99,5	1,02	2,2	114,6	91,0	0,87	1,7	95,2	82,6	0,72	1,2	54,9	64,9	0,41	0,4
	1413	104,4	109,6	0,80	1,4	89,4	99,7	0,68	1,1	74,4	89,8	0,57	0,8	43,0	69,3	0,32	0,3
50	2855	148,8	98,2	1,14	2,7	125,2	90,7	0,95	2,0	101,7	83,1	0,77	1,4	53,2	67,3	0,40	0,4
	2119	124,9	104,7	0,95	1,9	105,4	96,1	0,80	1,4	86,0	87,6	0,65	1,0	45,0	69,8	0,34	0,3
	1413	97,6	113,9	0,75	1,2	82,6	104,0	0,63	0,9	67,2	94,1	0,51	0,6	35,5	73,2	0,26	0,2
59	2855	137,9	103,6	1,05	2,3	114,3	96,1	0,87	1,7	90,8	88,3	0,69	1,1	41,6	72,5	0,31	0,3
	2119	116,0	109,6	0,89	1,7	96,2	101,1	0,74	1,2	76,4	92,5	0,58	0,8	35,1	74,3	0,26	0,2
	1413	90,4	118,4	0,69	1,1	75,4	108,5	0,58	0,8	60,1	98,4	0,45	0,5	27,3	77,0	0,21	0,1
68	2855	126,9	109,0	0,97	2,0	103,4	101,5	0,79	1,4	79,5	93,7	0,60	0,9	28,7	77,4	0,22	0,1
	2119	106,8	114,6	0,82	1,5	87,0	106,0	0,67	1,0	67,2	97,3	0,51	0,6	23,9	78,4	0,18	0,1
	1413	83,6	122,7	0,64	0,9	68,2	112,6	0,52	0,6	52,9	102,6	0,40	0,4	18,1	79,9	0,14	0,06

T<sub>z</sub> – inlet water temperature; T<sub>p</sub> – outlet water temperature; T<sub>p1</sub> – inlet air temperature; T<sub>p2</sub> – outlet air temperature; P<sub>g</sub> – heating capacity; Q<sub>w</sub> – water flow; Q<sub>a</sub> – air flow rate; Δp – pressure drop in the heat exchanger

Volcano VR3																	
Parameters T <sub>z</sub> /T <sub>p</sub> [°F]																	
194/158						176/140				158/122				122/86			
Tp1 [°F]	Qp [CFM]	Pg [MBH]	Tp2 [°F]	Qw [CFM]	Δp [psi]	Pg [MBH]	Tp2 [°F]	Qw [CFM]	Δp [psi]	Pg [MBH]	Tp2 [°F]	Qw [CFM]	Δp [psi]	Pg [MBH]	Tp2 [°F]	Qw [CFM]	Δp [psi]
32	3355	256,3	102,2	1,95	4,7	220,1	92,8	1,68	3,6	185,3	83,1	1,41	2,7	114,6	63,7	0,86	1,1
	2413	206,8	111,4	1,58	3,2	179,1	100,8	1,37	2,5	151,2	90,0	1,15	1,8	93,8	68,0	0,71	0,8
	1766	168,9	120,6	1,29	2,2	146,4	108,9	1,11	1,7	123,9	97,0	0,94	1,2	77,1	72,5	0,58	0,5
41	3355	238,5	106,9	1,82	4,2	204,0	97,3	1,55	3,1	169,2	87,8	1,28	2,2	97,9	68,0	0,74	0,8
	2413	193,8	115,3	1,48	2,8	166,2	104,7	1,27	2,1	138,2	93,9	1,05	1,5	80,2	71,8	0,60	0,6
	1766	158,3	124,0	1,21	1,9	135,8	112,3	1,04	1,5	112,9	100,2	0,86	1,1	65,9	75,6	0,49	0,4
50	3355	222,5	111,4	1,70	3,7	187,7	101,8	1,43	2,7	152,9	92,1	1,16	1,9	80,9	72,3	0,61	0,6
	2413	180,8	119,5	1,38	2,5	153,2	108,7	1,17	1,8	124,9	97,9	0,95	1,3	66,2	75,4	0,49	0,4
	1766	147,7	127,6	1,13	1,7	125,2	115,7	0,95	1,3	102,4	103,6	0,78	0,9	54,3	78,4	0,41	0,3
59	3355	206,1	115,9	1,58	3,2	171,3	106,3	1,31	2,3	136,5	96,6	1,04	1,5	62,8	76,3	0,47	0,4
	2413	167,9	123,4	1,28	2,2	139,9	112,6	1,07	1,6	111,6	101,8	0,85	1,0	51,5	78,8	0,39	0,3
	1766	137,2	131,0	1,05	1,5	114,6	119,1	0,87	1,1	91,4	106,9	0,69	0,7	42,3	81,1	0,32	0,2
68	3355	189,7	120,4	1,45	2,7	154,9	110,8	1,18	1,9	119,4	100,9	0,96	1,2	43,7	80,1	0,33	0,2
	2413	154,6	127,4	1,18	1,9	126,6	116,6	0,97	1,3	97,9	105,6	0,74	0,8	35,5	81,5	0,26	0,1
	1766	126,6	134,4	0,97	1,3	103,7	122,4	0,79	0,9	80,5	110,1	0,61	0,6	28,3	82,8	0,21	0,09

Parameter	Unit of measure	VOLCANO VR mini	VOLCANO VR1	VOLCANO VR2	VOLCANO VR3	VOLCANO VR-D
Number of rows in the heater		2	1	2	3	---
Maximum air flow rate	CFM	1236	3119	2855	3355	3826
Heating power range	MBH	10-68	17-102	27-171	44-256	---
Maximum temperature of the heating agent	°F	266				---
Maximum operating pressure*	psi	232				---
Maximum horizontal air stream range	ft	46	75	72	82	92
Maximum vertical air stream range	ft	26	39	36	39	49
Water capacity	in <sup>3</sup>	68	76	131	188	---
Connection diameter	"	3/4				---
Weight of the device (without water)	lb	39	61	64	68	49
Power supply voltage	V/Hz	1 ~ 115/60 / 1 ~ 240/60				
EC Motor rated power	HP	0,13	0,34		0,50	
EC Motor rated current	A	0,51	1,3		1,7	
EC Motor speed	rpm	1450	1430		1400	
EC Motor IP	---	44				

NOTE Data concerning VOLCANO working parameters for a heating agent with a different temperature can be provided upon request

Volcano VR Mini				
fan speed		III	II	I
air flow	CFM	1236	971	647
noise level for Volcano EC*	dB(A)	50	40	27
EC motor electric power**	HP	0,12	0,07	0,05
horizontal air stream range	ft	46	26	16
vertical air stream range	ft	26	16	10

\* reference conditions: room volume 52 972 ft<sup>3</sup>, measurement taken at a distance of 16ft

\*\* EC motor electric power for the air flow mentioned in the table

Volcano VR1				
fan speed		III	II	I
air flow	CFM	3119	2295	1648
noise level for Volcano EC*	dB(A)	54	49	38
EC motor electric power**	HP	0,33	0,25	0,21
horizontal air stream range	ft	75	66	49
vertical air stream range	ft	39	30	23

\* reference conditions: room volume 52 972 ft<sup>3</sup>, measurement taken at a distance of 16ft

\*\* EC motor electric power for the air flow mentioned in the table

Volcano VR2				
fan speed		III	II	I
air flow	CFM	2855	2119	1413
noise level for Volcano EC*	dB(A)	54	49	38
EC motor electric power**	HP	0,33	0,25	0,21
horizontal air stream range	ft	72	62	46
vertical air stream range	ft	36	26	20

\* reference conditions: room volume 52 972 ft<sup>3</sup>, measurement taken at a distance of 16ft

\*\* EC motor electric power for the air flow mentioned in the table

Volcano VR3				
fan speed		III	II	I
air flow	CFM	3355	2413	1766
noise level for Volcano EC*	dB(A)	55	49	43
EC motor electric power**	HP	0,48	0,37	0,28
horizontal air stream range	ft	82	72	56
vertical air stream range	ft	39	30	23

\* reference conditions: room volume 52 972 ft³, measurement taken at a distance of 16ft

\*\* EC motor electric power for the air flow mentioned in the table

*\* for vertical air guides adjustment*

Volcano VR-D				
fan speed		III	II	I
air flow	CFM	3826	2707	2001
noise level for Volcano EC*	dB(A)	56	50	43
EC motor electric power**	HP	0,48	0,37	0,28
horizontal air stream range	ft	92	79	62
vertical air stream range	ft	49	36	30

\* reference conditions: room volume 52 972 ft³, measurement taken at a distance of 16ft

\*\* EC motor electric power for the air flow mentioned in the table

#### 4. ASSEMBLY

**NOTE** Installation location should be suitably selected with special consideration of potential loads and vibrations.

Prior to any installation or maintenance works, disconnect the device from the power supply and secure it against accidental power-up.

Use filters in the hydraulic system. Before you connect the hydraulic lines (especially supply lines) to the device, you should clean/rinse the installation by draining two litres out of it.

**NOTE** It is necessary to maintain a minimum distance of 0.4m from the wall or the ceiling; otherwise the device can malfunction, the fan can be damaged or its operating noise can increase.

**If the device will be installed on a wall or under a ceiling, observe the following factors:**

##### mounting heigh

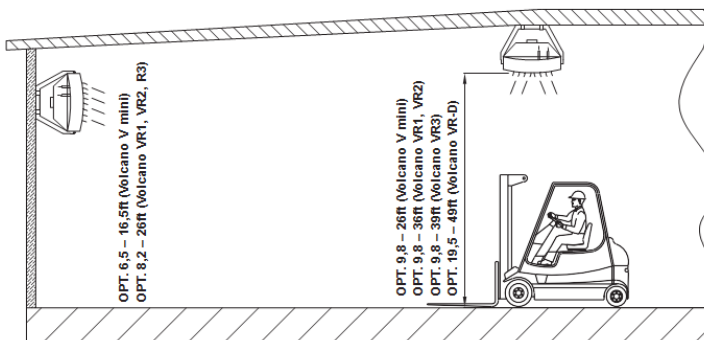

*\* for vertical air guides adjustment*

**distance between units** – recommended distance 19,6-39ft (Volcano VR1, VR2, VR3), 9,8-23ft (Volcano VR Mini), in order to ensure even hot air diffusion

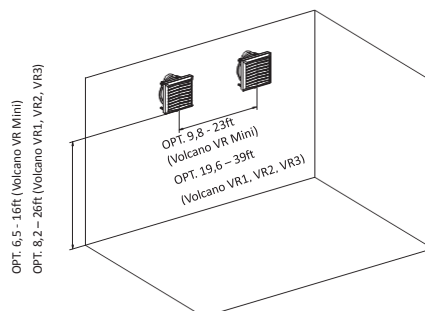



### range of air stream

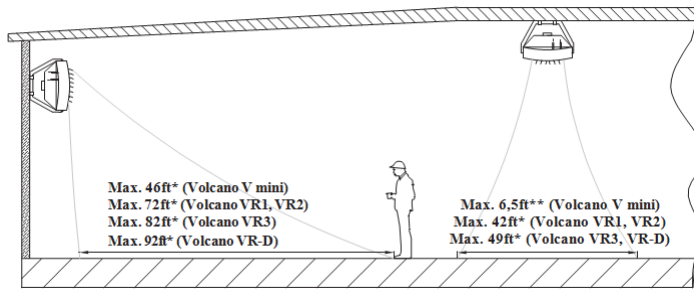

\* for horizontal air guide adjustment

\*\* for symmetric air guide adjustment at an angle of 45°

- device noise level (depending on acoustic characteristics of a room)
- operation mode of the heating device, e.g. it can also operate as an air mixing device preventing air stratification
- direction of air distribution should be controlled in a way that prevents draughts. Air stream must not be directed at walls, brackets, girders, cranes, shelves, machines, etc.

### Examples of arrangement of air heating units mounted on a wall

Top view

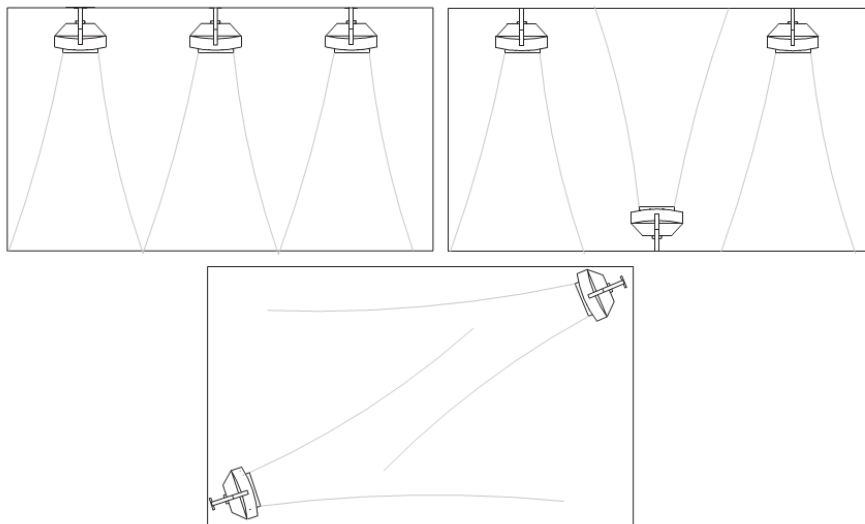

#### 4.1 INSTALLATION WITH A BRACKET

Each unit is supplied with bracket. In order to attach a bracket to the device, use crown drill bits to drill holes in the top and bottom panels of the heating unit (in places marked with arrows), and insert sleeves (6) into the holes. Slide holder arms onto the sleeves. Insert M10x80mm screws (4) into the top and bottom sleeves, and fix the bracket position in relation to the heater while tightening the screws. When you adjust the device in the right position, fit plugs into the bracket.

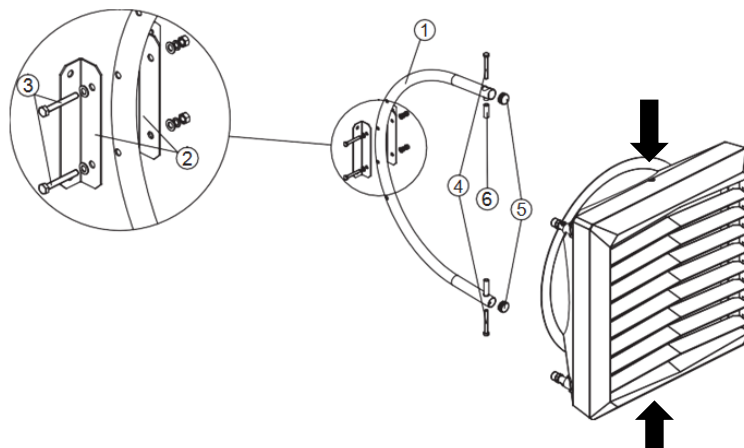

#### The bracket unit consists of:

1. ARM (1 piece);
2. HOLDER;
3. M8x60mm SCREW WITH A WASHER AND NUT FASTENING THE CLAMP (2 sets);
4. M8x60mm SCREW FASTENING THE HOLDER TO THE UNIT HEATER (2 pieces);
5. PLUG (2 pieces);
6. MOUNTING SLEEVE (2 pieces)

VOLCANO VR Mini  
 VOLCANO VR1  
 VOLCANO VR2  
 VOLCANO VR3  
 VOLCANO VR-D

rotation of the device when mounted on a console

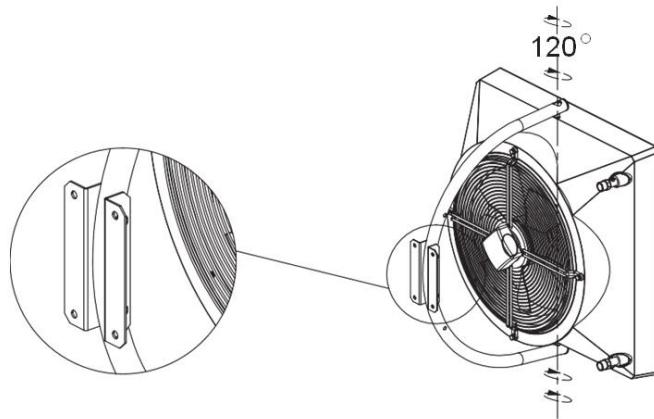

#### 4.2 INSTALLATION INSTRUCTIONS AND MOUNTING DISTANCES

**Installation of the heating medium supply system** While installing the piping for the heating medium, secure the exchanger connection against twisting **1**. The piping should not overload the heater connections. **It is possible to connect the piping with flexible connections (adjustable angle of the airflow).**

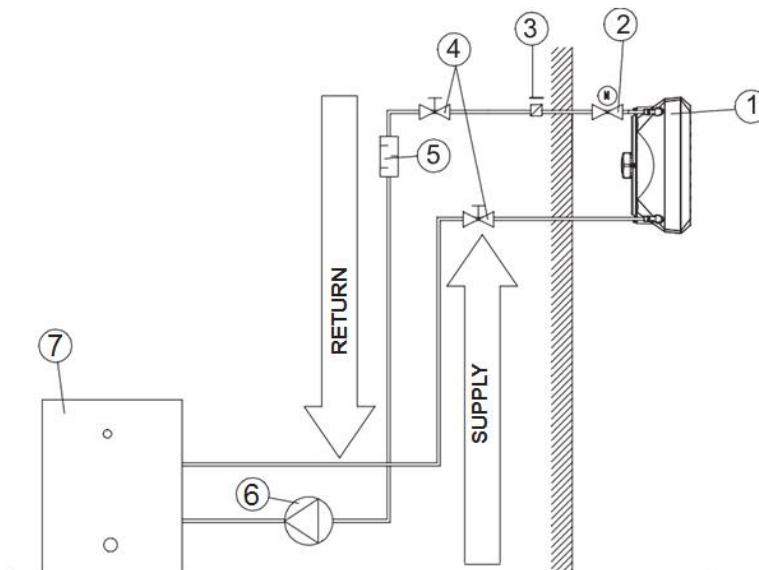
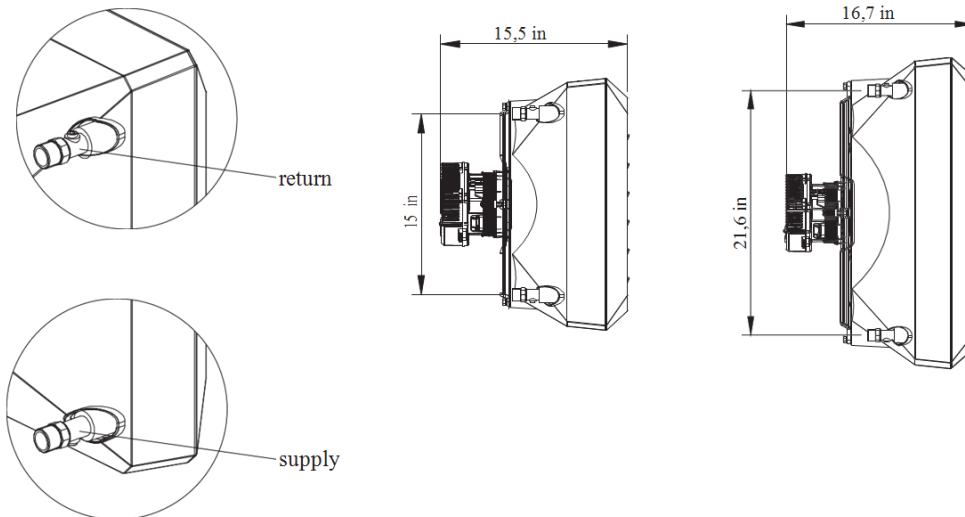

#### EXAMPLE OF A HYDRAULIC SYSTEM:

1. UNIT HEATER; 2. POWER-OPERATED VALVE; 3. VENT VALVE; 4. CUT-OFF VALVE; 5. FILTER; 6. CIRCULATION PUMP; 7. BOILER

### Heater vent/ heating medium drain

The device will be vented when you loosen the vent bolt 1 placed on the connection pipe. The heating medium is drained through the drain plug 2, placed on the bottom connection pipe. When starting the device after the heating agent has been drained, remember to vent the heater. You need to pay special attention to secure the device against water accidentally getting into the heater casing during the agent draining process.

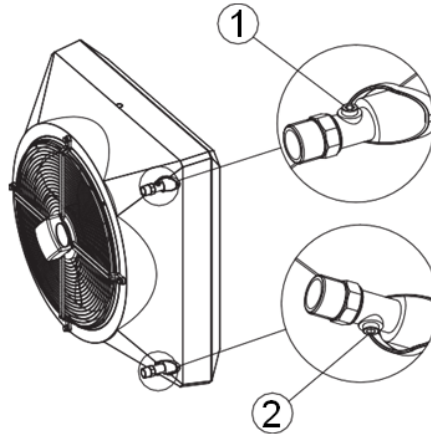

### Connecting to the power supply

**NOTICE** The installation must be equipped with disconnectors at all power supply poles. **Recommended safety: overload disconnector VOLCANO VR Mini – 1 A, VOLCANO VR1, VR2 – 2 A, VOLCANO VR3, VR-D - 4A) and differential current safety. VOLCANO VR Mini, VR1, VR2, VR3, VR-D (fan) are equipped with a terminal block accepting 7 x 14 AWG electric wires. NOTICE We recommend connecting the wires to the terminal block with pre-installed bushings.**

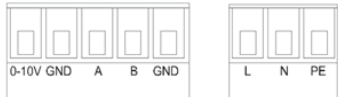
VOLCANO VR Mini, VR1, VR2, VR3, VR-D/ EC	Power supply: 3 x 16 AWG Control: 0-10Vdc: LiYCY 2x18 AWG (shielded)	
---	---	---

### Adjusting the air guides

Volcano air guides are mounted on the pivot (1), which provides smoothly change of air direction. In order to change position of air blade should turn it in both hands (grasping the edges of the enclosure) to turn the blade at the same time on both pins.

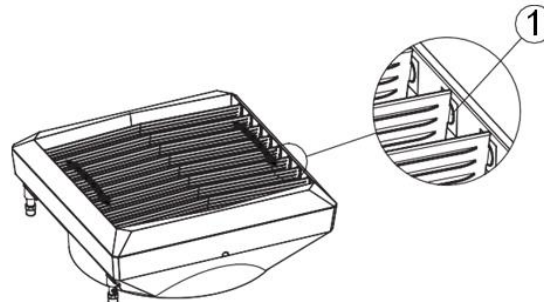

VOLCANO VR Mini, VR1, VR2, VR3, VR-D

## 5. AUTOMATICS

### 5.1 ELEMENTS OF AUTOMATICS

Electric connections may only be made by well-trained electricians, and according to:

- Occupational health and safety regulations
- Assembly instructions
- Technical documentation for each of the automatic elements

**NOTE** Before starting the assembly process and connecting the system, familiarize yourself with the original documentation attached to the automatic devices.

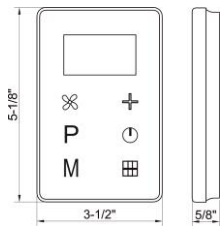
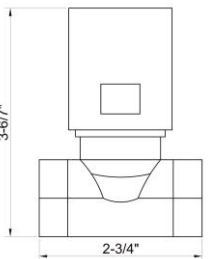
MODEL	DIAGRAM	TECHNICAL DATA	COMMENTS
WALL-MOUNTED CONTROL PANEL		<p><b>HMI-WING EC</b></p> <ul style="list-style-type: none"> <li>• Device operation: Capacitive touch buttons</li> <li>• Power supply: 230 V AC</li> <li>• Temperature measurement: 14 °F ... 210 °F ; NTC10K</li> <li>• Outputs: <ul style="list-style-type: none"> <li>- 1 analog output 0-10V (8 bit, I<sub>max</sub> = 20mA)</li> <li>- 2 relays outputs (250 VAC, AC1 500 VA dla 230 VAC)</li> </ul> </li> <li>• Inputs: 1 digital input type "dry contact", I<sub>max</sub> = 20 mA</li> <li>• Communication: Modbus RTU</li> <li>• Parameters of working environment: temperature: 32 - 140 °F, humidity: 10 - 90%, without condensation</li> </ul>	<ul style="list-style-type: none"> <li>• used for control all types of WING EC curtains</li> <li>• touch control panel</li> <li>• the main on / off switch (ON / OFF)</li> <li>• three-stage adjustable fan speed of the EC motor</li> <li>• built-in thermostat with possibility weekly programing</li> <li>• continuous mode</li> <li>• function of heating and ventilation</li> <li>• door sensor operation</li> <li>• two-stage adjustable of heating power</li> <li>• RS 485 with ModbusRTU</li> <li>• Suggested cross sections of electrical cables:: <ul style="list-style-type: none"> <li>- L, N : 0.08x0.04 in<sup>2</sup></li> <li>- H1, H2 : 0.08x0.04 in<sup>2</sup></li> <li>- AO, GND : 0.08x0.02 in<sup>2</sup> LIYCY</li> <li>- Door sensor : 0.08x0.02 in<sup>2</sup> LIYCY</li> <li>- RS 485 : 0.12x0.03 in<sup>2</sup> LIYCY</li> </ul> </li> </ul>
TWO-WAY VALVE WITH ACTUATOR		<p><b>TWO-WAY VALVE</b></p> <ul style="list-style-type: none"> <li>• Terminal diameter: 3/4"</li> <li>• Mode of operation: two-way ON/OFF</li> <li>• Maximum differential pressure: 13psi</li> <li>• Pressure class: PN 16</li> <li>• Kvs flow ratio: 2.65 CFM</li> <li>• Maximum temperature of heating medium: 221°F</li> <li>• Parameters of working environment: from 32 to 140°F</li> </ul> <p><b>VALVE ACTUATOR</b></p> <ul style="list-style-type: none"> <li>• Power consumption: 7 VA</li> <li>• Supply voltage: 230VAC +/-10%</li> <li>• Closing/opening time: 4-5/9-11 s</li> <li>• Position without power: closed</li> <li>• Level of protection: IP54</li> <li>• Parameters of working environment: from 89 to 284°F</li> </ul>	<ul style="list-style-type: none"> <li>• It is recommended to install a two-way valve on the return pipeline.</li> <li>• The drawings with the elements of automatics contain only visualizations of sample products.</li> <li>• It is recommended to connect the supply, using a conductor of the min. size 0.08x0.03 in<sup>2</sup>.</li> <li>• The drawings with the elements of automatics contain only visualizations of sample products.</li> </ul>

## 6. START-UP, OPERATION, MAINTENANCE

### 6.1 START-UP/PUTTING INTO OPERATION

- Prior to any installation or maintenance works, disconnect the device from the power supply and secure it against accidental power-up.
- Use filters in the hydraulic system. Before you connect the hydraulic lines (especially supply lines) to the device, you should clean/rinse the installation by draining a few litres out of it.
- Install vent valves at the highest point of the installation.
- Install cut-off valves directly behind the device, so it can be easily disassembled.
- Secure the device against pressure increase according to the permitted maximum pressure value of 232psi.
- Hydraulic pipes need to be free from any stresses and loads.
- Prior to the first start-up of the heater, check the hydraulic connections (vent and collector air-tightness, installed fittings).
- Prior to the first start-up of the heater, check the electric connections (connection of automatic devices, power supply, fan).
- It is suggested to use additional external current differential protection.

### 6.2 OPERATION AND MAINTENANCE

- Device casing does not require any maintenance.
- Heat exchanger needs to be regularly cleaned of dirt and grease. Especially before the heating season, the heat exchanger needs to be cleaned with the use of compressed air on the side of the air guides (but the device does not need to be disassembled). Pay attention to the exchanger's lamellas, as these are delicate.
- If lamellas bend, straighten them with a special tool.
- The fan motor does not require any maintenance. It may only require cleaning of the protective mesh, fan blades and dust and grease deposits.
- If the device is not used for a long time, disconnect the voltage supply.
- Heat exchanger does not have fire protection.
- It is recommended to periodically blow through the heat exchanger, preferably with compressed air.
- The heat exchanger can freeze (fracture) when the room temperature falls below 0°C and the heating agent temperature decreases at the same time.
- The level of air pollutants should meet the criteria allowable concentrations of pollutants in indoor air, for non-industrial areas, the level of dust concentration up to 0.3 g / m<sup>3</sup>. It is forbidden to use device for the duration of the construction works except for the start-up of the system.
- The equipment must be operated in rooms used throughout the year, and in which there is no condensation (large fluctuations in temperature, especially below the dew point of the moisture content).
- The device should not be exposed to direct UV rays.
- The device should be operated at the supply water temperature up to 266 °F with working fan.

## 7. INDUSTRIAL SAFETY INSTRUCTION

### Special instructions concerning safety NOTE

- Prior to any work connected with the device, the device must be disconnected from the power supply and be secured properly. Wait until the fan stops.
- Use stable assembly platforms and hoists.
- Depending on the heating agent temperature, piping, parts of the casing, heat exchanger surface can be very hot, even after the fan stops.
- There may be some sharp edges! During transport, use protective gloves, protective clothing and safety shoes.
- The health and safety instructions must be followed.
- Loads can be fastened only in places designed for it in a transport unit. While devices are lifted by an assembly unit, their edges need to be secured. Distribute the load evenly.
- The device needs to be protected against moisture and dirt and should be stored in rooms secured against atmospheric influences.
- Disposal: Take care to dispose of used materials, packaging material and spare parts in a safe way, one which is not harmful to the environment and is in accordance with local regulations.

## 8. SERVICING

### 8.1 PROCEDURES IN CASE OF DEFECTS

VR Mini, VR1, VR2, VR3, VR-D		
Problem	Check points	Description
Heat exchanger leaking	<ul style="list-style-type: none"> <li>• assembly of the exchanger connections with two wrenches (adjustment), which safeguards against internal twisting of the collectors,</li> <li>• Check if the leakage may be associated with mechanical damage to the exchanger,</li> <li>• Vent valve or drain plug leaking,</li> <li>• Heating agent parameters (pressure and temperature) – should not exceed permitted values,</li> <li>• type of heating agent (it cannot be aggressive to Al and Cu),</li> <li>• Circumstances when the leakage appears (e.g. during the first, tentative installation start-up, when the installation is filled up after the heating agent has been drained) and outside temperature at the time of failure (risk that the exchanger may freeze),</li> <li>• Possibility of operating in aggressive conditions (e.g. high concentration of ammonia in the air in a sewage-treatmentplant),</li> </ul>	Pay special attention that the exchanger may freeze during winter time. 99% of registered leakages appear during installation start-up/ pressure tests. The defect can be removed by pulling back vent or drain valve.
Fan works too loud	<ul style="list-style-type: none"> <li>• check the device assembly for conformity with the instructions in operation and maintenance manual (e.g. distance from wall/ceiling),</li> </ul>	min. 15 inches
	<ul style="list-style-type: none"> <li>• Device appropriately level led,</li> <li>• Correctness of electric connections and qualifications of the wireman,</li> <li>• Inlet current parameters (e.g. voltage, frequency),</li> <li>• noise at lower gears (possible controller failure?),</li> <li>• Noise only at higher gears (regular situation explained by aerodynamic characteristics of the device, if there outlet air chokes),</li> <li>• type of other devices operating in the building (e.g. induced draught fans) – intensified noise caused by simultaneous operation of many machines,</li> <li>• Does the fan rub against the casing?</li> <li>• Is the fan evenly screwed to the casing?</li> </ul>	Level of operating noise of VOLCANO devices is perceived subjectively. If the device is made of plastic, it should operate quietly. It is recommended to unscrew the clamping screws and tightening them up again. If the fault does not disappear, you should make a complaint.
Fan does not work	<ul style="list-style-type: none"> <li>• Correctness and quality of electric connections and qualifications of the wireman,</li> <li>• Inlet current parameters (e.g. voltage, frequency) on the clamp block of fan engine,</li> <li>• Correctness of operation of other devices installed in the building,</li> <li>• Correctness of wire connections on the engine side acc. to the manual, in comparison to wires clamped in the engine terminal strip,</li> <li>• PE conductor voltage (if present, may mean there is a break-down),</li> <li>• Is N conductor correctly connected to the fan.</li> </ul>	Electrical connection need to be done strictly according to the drawings in the manual.
Damaged casing	<ul style="list-style-type: none"> <li>• Circumstances when it was damaged – notes on the bill of lading, stock issue confirmation, condition of the box,</li> </ul>	If the casing is damaged, make photos of the box and device, and photos confirming that the device serial number on the device and on the box are the same. If the device was damaged during transport, it is necessary to write down an appropriate statement by the driver, who delivered the damaged device
Actuator does not open the valve	<ul style="list-style-type: none"> <li>• Correctness of electric connections and qualifications of the wireman,</li> <li>• Correctness of the thermostat operation (characteristic tick sound during change-over),</li> <li>• Inlet current parameters (e.g. voltage),</li> </ul>	The most important is to check whether the actuator responded to the electric impulse.



it is forbidden to place, dispose of and store worn-out electric and electronic equipment, together with other waste. Dangerous compound contained in electronic and electric equipment have a very adverse impact on plants, micro-organisms, and, most importantly, on humans, as they damage our central and peripheral nervous system, as well as circulatory and internal system. Additionally, they cause serious allergic reactions. Worn-out equipment is to be delivered to a local collection point for used electric equipment, which carries out a selective collection of waste.

**REMEMBER!**

The user of equipment intended for households, and which has been worn out, is obliged to transfer such equipment to a collecting unit that collects worn-out electric and electronic equipment. The selective collecting and further processing of waste from households contributes to the protection of environment, reduces the penetration of hazardous substances into the atmosphere and surface waters.

**8.2 COMPLAINT PROCEDURE**

In order to report a problem with the device or elements of automation, please fill in and send the appropriate form, using one of the three available ways:

1. E-mail: [vts.pl@vtsgroup.com](mailto:vts.pl@vtsgroup.com)
2. Fax: (+48) 12 296 50 75
3. Website: [www.vtsgroup.pl](http://www.vtsgroup.pl)\PRODUKT\VTS Service\formularz zgłoszeniowy

Our service department will contact you immediately.

In the case of damage in transport, send a complaint notification, including the delivery documentation (bill of lading, inventory issue) and photographs showing the defects. Should you have any questions, please contact us, using this telephone number: 0 801 080 073

**IMPORTANT!**

The complaint procedure shall be initiated when the Service Department has received a correctly filled complaint notification, a copy of the purchase invoice and the Warranty Card, filled by the company that carried out the installation.

## 9. ELECTRICAL DIAGRAMS

### 9.1. Connection of Volcano VR Mini, VR1, VR2, VR3, VR-D to the HMI VR controller

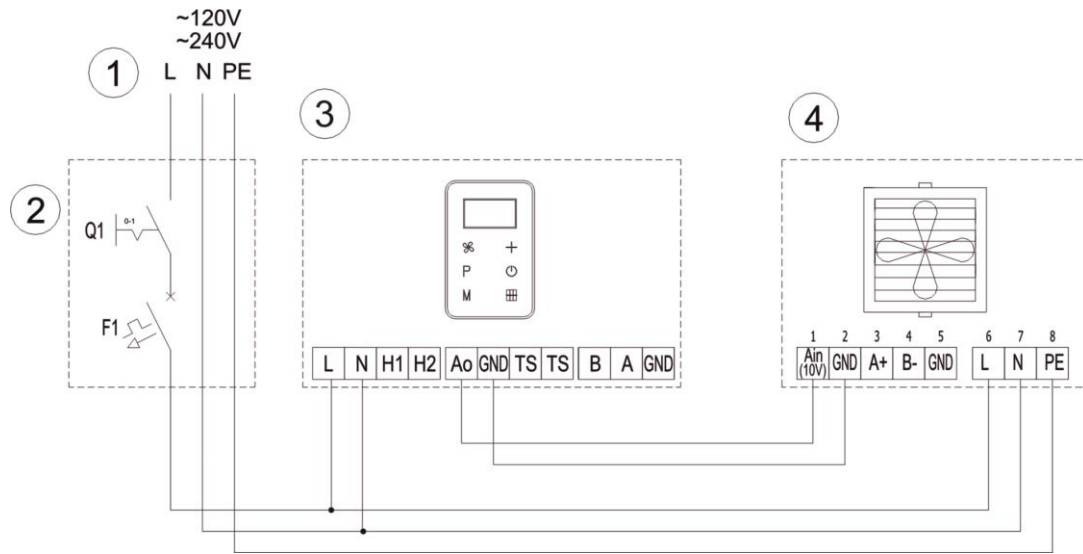

1-supply: 120V – 60Hz /240V - 60Hz\*, 2-main switch, fuses\*, 3-HMI VR controller, 4-Volcano fan  
 \* the device does not include: the main switch, fuses and feeder cable

### 9.2. Connection of Volcano VR Mini, VR1, VR2, VR3 to the HMI VR controller and valve actuator

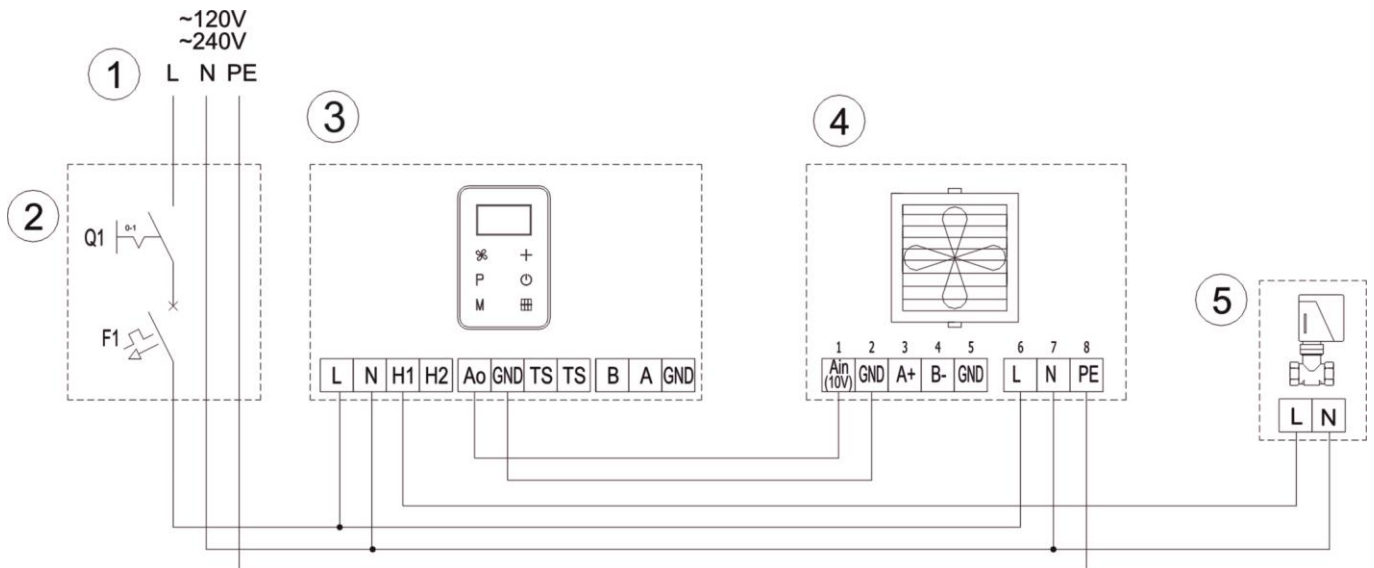

1-supply: 120V – 60Hz /240V - 60Hz\*, 2-main switch, fuses\*, 3-HMI VR controller, 4-Volcano fan, 5-valve with actuator  
 \* the device does not include: the main switch, fuses and feeder cable

9.3. Connection of Volcano VR Mini, VR1, VR2, VR3 to the HMI VR controller and external temperature sensor

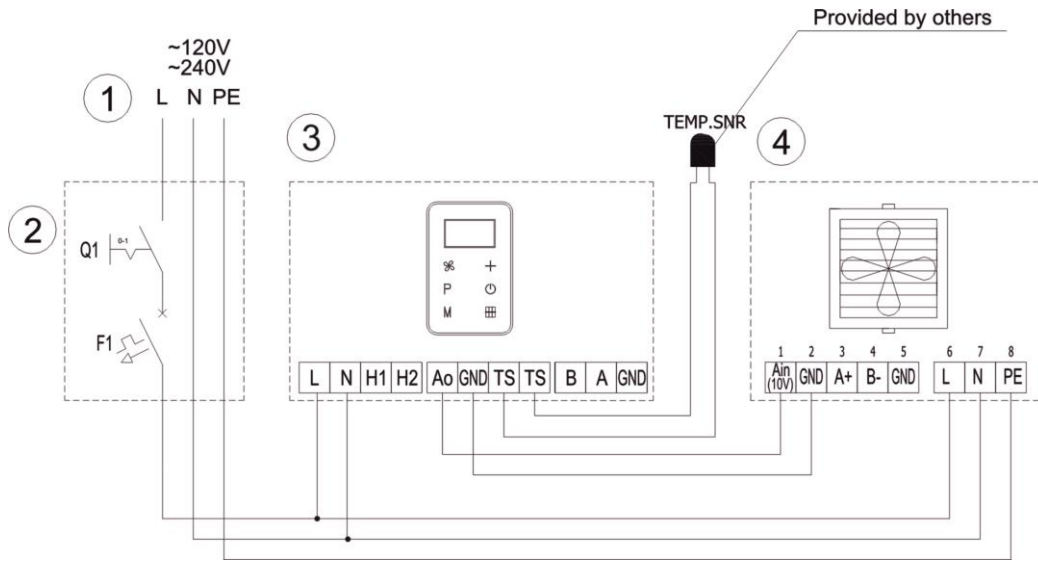

1-supply: 120V – 60Hz /240V - 60Hz \*, 2-main switch, fuses\*, 3-HMI VR controller, 4-Volcano fan  
 \* the device does not include: the main switch, fuses and feeder cable

9.4. Connection of Volcano VR Mini, VR1, VR2, VR3 to the HMI VR controller, valve actuator and external temperature sensor

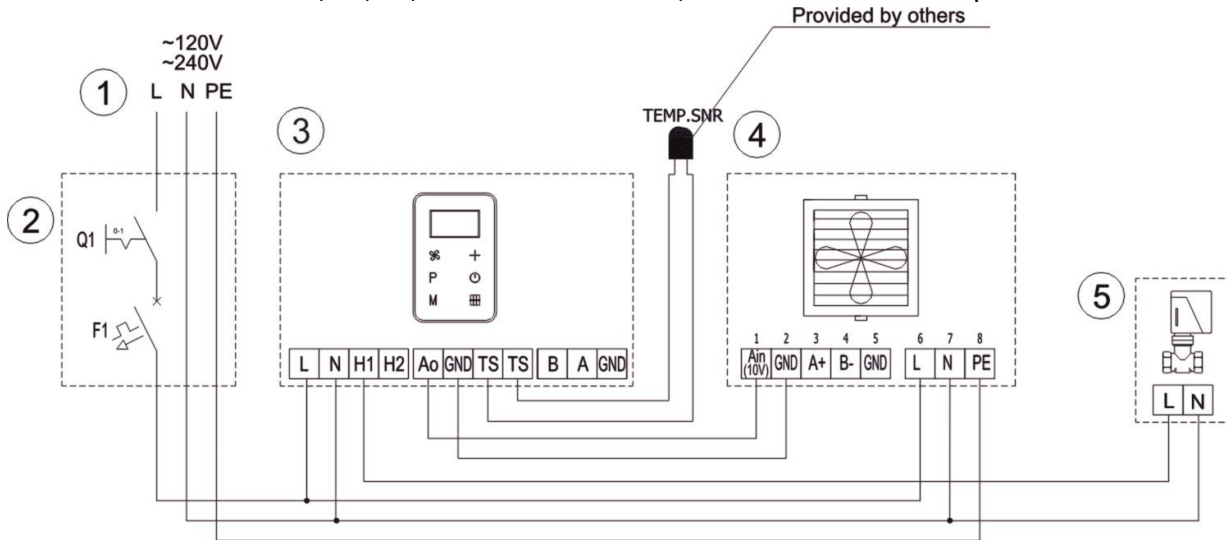

1-supply: 120V – 60Hz /240V - 60Hz \*, 2-main switch, fuses\*, 3-HMI VR controller, 4-Volcano fan, 5-valve with actuator  
 \* the device does not include: the main switch, fuses and feeder cable



VTS POLSKA Sp. z o.o.  
Al. Grunwaldzka 472 A  
80-309 Gdańsk  
Polska  
www.vtsgroup.com

The company submitting the notification:
The company that installed the equipment:
Date of notification:
Type of device:
Factory number*:
Date of purchase:
Date of installation:
Place of installation:
Detailed description of defect:
Contact person:
Name and surname:
Telephone:
E-mail:

\* This field must be filled, if the complaint notification refers to the following equipment: VOLCANO VR1 and VR2 unit, and WING air curtains.

10. VTS STANDARD WARRANTY TERMS AND CONDITIONS FOR EUROHEAT PRODUCTS

Warranty card

1. Stamp of the company to carry out installation		VTS POLSKA Sp. z o.o. Al. Grunwaldzka 472 A, 80-309 Gdańsk Polska  www.vtsgroup.com	
2. Factory number of device			
3. Place of installation		4. Date of installation	
5. Address, street		6. Apartment number	
7. City		8. Postal code	

<p>Based on these Warranty Terms and Conditions, the company from the VTS Group (hereinafter: VTS) specified in the warranty card hereby guarantees to the owner (hereinafter: Customer) that the Volcano VR, WING W100 - 200, WING E100 – 200, WING C100 - 200 devices (hereinafter: devices) sold by VTS will work without malfunctions.</p> <p><b>§ 1 Warranty period</b></p> <ol style="list-style-type: none"> <li>The warranty period for the devices shall be 5 years following the date when the devices were purchased by the Customer.</li> <li>The warranty period for the automation elements shall be 3 years following the date when the devices were purchased by the Customer.</li> <li>The lifetime warranty shall cover the casing of devices and it shall apply throughout the whole device lifetime, i.e. for 15 years.</li> <li>The purchase date shall mean the date when VTS or a VTS distributor issued a VAT invoice documenting the sale of the device to the Customer.</li> </ol> <p><b>§ 2 Scope of warranty</b></p> <ol style="list-style-type: none"> <li>If a complaint is recognised as justified, VTS shall, at its option, either replace the devices or their defective parts or repair them on the site of their installation or in another place, after they are sent for repair.</li> <li>If the warranty service is provided on the site of device installation in the country of VTS's registered office, VTS shall cover the costs of transporting VTS Licensed Service Technicians and the costs of transporting spare parts. The current list of VTS Licensed Service Centres, hereinafter service centres, is available on <a href="http://www.vtsgroup.com">www.vtsgroup.com</a> and in VTS business offices.</li> <li>A warranty report is only processed if the device has been purchased in the country of VTS's registered office.</li> <li>A warranty service does not interrupt, suspend or change the warranty period; the warranty for replaced parts shall expire along with the expiry of the device warranty.</li> <li>A warranty granted by VTS shall neither exclude nor limit or suspend the Customer's rights arising from the regulations regarding implied warranty for defects of a sold item.</li> <li>These Warranty Terms and Conditions shall be binding for the parties of all contracts connected with the devices, unless the contract specifies otherwise, with the consent of VTS.</li> </ol> <p><b>§ 3 Exclusions</b></p> <ol style="list-style-type: none"> <li>This warranty shall not include: <ol style="list-style-type: none"> <li>Any parts subject to normal wear and tear, consumables.</li> <li>Any damage arising through no fault of VTS and device defects occurring for reasons other than inherent to the devices.</li> <li>Device damage resulting from the impact of the surroundings, improper transport, storage.</li> <li>Mechanical damage arising from incorrect operation and use of the device, repair and maintenance incompatible with the technical documentation enclosed with the device, the Operation &amp; Maintenance Manual or by individuals without proper qualifications.</li> <li>Devices whose installation or start-up was conducted in a manner incompatible with the technical documentation enclosed with the device, the Operation &amp; Maintenance Manual or by individuals without proper qualifications.</li> <li>Devices which were not inspected at least once a year and were not subject to current maintenance activities as required by the Operation &amp; Maintenance Manual or whose technical inspections or maintenance activities were conducted by individuals without proper qualifications.</li> <li>Devices which were subject to modifications, changes of operation parameters, repair or replacement of parts without the written consent of VTS.</li> <li>Any damage to or defects of devices which do not affect the functionality and correct operation of the devices.</li> </ol> </li> <li>This warranty shall not cover VTS's obligation to ensure current maintenance, inspections or programming of devices.</li> <li>This warranty shall cover neither VTS's liability for any damage caused by device downtime while waiting for warranty services nor any damage to any property of the Customer other than the devices.</li> <li>In order to exercise their rights under the Warranty, the Customer shall file a complaint in the country where they have purchased the device. If a report is filed in another country than the country of purchase, VTS is under no obligation to provide service under the warranty.</li> </ol> <p><b>§ 4 Complaints</b></p> <ol style="list-style-type: none"> <li>File any complaints online by sending the electronic application available on <a href="http://www.vtsgroup.com">www.vtsgroup.com</a> or on the phone by calling the complaint department along with sending the electronic application specified above.</li> <li>A complaint report ought to include: <ul style="list-style-type: none"> <li>- device type and serial number,</li> <li>- date of device purchase and start-up,</li> <li>- device installation site,</li> <li>- business name of the seller and installer of the device,</li> <li>- Customer's phone number and the Customer's contact person,</li> <li>- description of the device malfunction (description of the incorrect functioning, specifying the damaged part).</li> </ul> </li> <li>If the Customer claims that the device was damaged during transport, complete device in the original packaging securing the device against damage shall be delivered to the place of repair specified by VTS. The device serial number must be consistent with the number on the original packaging and in the Warranty Card.</li> <li>Filing a complaint, the Customer shall deliver a copy of the VAT invoice documenting the purchase of the device covered by the complaint.</li> </ol> <p><b>§ 5 Warranty service</b></p> <ol style="list-style-type: none"> <li>Services arising from this warranty shall be provided within the 14 days following the report date. In special cases, this time limit may be extended to 30 days.</li> <li>Any parts removed from the device by the service technicians within warranty services and replaced with new parts shall become the property of VTS.</li> <li>Any costs arising from a groundless complaint report or interruptions in the work of service technicians at the Customer's request shall be borne by the Customer in line with the technical service price list available on <a href="http://www.vtsgroup.com">www.vtsgroup.com</a></li> <li>VTS shall have the right to refuse to perform a warranty service if the Customer fails to pay for the device or for any previous technical service.</li> <li>The Customer shall cooperate with the service technicians in terms of a warranty service performed on the site of the device installation, in particular by: <ol style="list-style-type: none"> <li>providing free access to the device in due time,</li> <li>preparing the site for service provision, in particular providing any additional structures to access a device installed higher than 1.5 m above the floor and, if necessary, to remove and re-install the devices,</li> <li>disconnecting and connecting the hydraulic system (water, glycol system) and the freon system, performing additional works to allow the service technicians to handle the complaint,</li> <li>presenting the documents provided together with the device (a warranty card filled out by the installer),</li> <li>making it possible for the service technicians to commence work immediately upon arrival, without unnecessary delay,</li> <li>providing, free of charge, all possible assistance in service provision (e.g. providing access to an electrical power source or lighting in the place of service provision),</li> <li>taking the actions necessary to protect people and objects and following OHS regulations at the place where the warranty service is being performed, which includes making sure that the service performance site meets the requirements defined in legal regulations.</li> </ol> </li> <li>The Customer shall promptly accept and confirm completion of the warranty service on the Service Card document. When in doubt as to the quality and completeness of the warranty service, the Customer has the right to complain to VTS. Provisions of § 4 hereof shall apply to such a complaint as appropriate.</li> </ol> <p><b>§ 6 Other provisions</b></p> <ol style="list-style-type: none"> <li>In the event of any discrepancies between the Proposal plus the Purchase Order and these VTS Standard Warranty Terms and Conditions, VTS Standard Warranty Terms and Conditions shall prevail. In such an event, any contradictory provisions of the Proposal and the Purchase Order shall not apply.</li> <li>In the event of any discrepancies between a contract signed by the Parties and these VTS Standard Warranty Terms and Conditions, VTS Standard Warranty Terms and Conditions shall prevail.</li> <li>The Operation &amp; Maintenance Manual is available on <a href="http://www.vtsgroup.com">www.vtsgroup.com</a>.</li> </ol>
---

11. TABLE OF INSPECTION AND MAINTANANCE

INSPECTIONS AND MAINTENANCE		
Date	Made by Company	Cleaning, Cleaning of the heat exchanger